



GE INDUSTRIAL MOTORS  
a WOLONG company

# GE Industrial Motors Quantum V

Performance, Efficiency, Reliability. Upgrade your assets with GEIM's Newest Vertical Motor



IEEE

NEMA  
Premium



+1 (888) 525-2915  
[www.gemotorswolong.com](http://www.gemotorswolong.com)

# GE Industrial Motors - Quantum V

## Key Features

- New and improved ball type non-reverse ratchet system allows reliable operation down to 150 rpm
- Rugged and reliable cast iron construction
- New improved thrust ratings offer the highest thrust ratings by power rating in the industry
- Patented bearing cooling system for TEFC motors eliminates the need for water cooled thrust bearings
- Improved oil reservoir and optimized bearing sizes eliminates the need for water cooled thrust bearings on most WPI/WPII ratings
- Class F insulation with Class B rise
- TEFC motors come standard with IP55 protection

## Optional Custom Features Available

- GEIM offers a fully-customizable product in a very short lead time. Optional features include but are not limited to:
- Complete range of base diameter and coupling BX diameter options
- Space heaters at a variety of voltages
- Insulated upper bearing system
- Insulated guide bearing
- Internally mounted shaft grounding ring
- 10, 100, or 120 ohm winding RTDs.
- 10, 100, or 120 ohm bearing RTDs.
- Normally Open or Normally Closed winding thermostats
- Winding thermistors
- Bearing thermocouples
- Oil temperature switches
- Standard and bronze stabilizer bushings for hollow shaft motors
- Custom voltages, service factors, and other electrical design options
- Special altitudes and ambients
- Stainless Steel hardware
- Extended leads
- Special paint chemistries and colors
- Custom Part Winding Starting and Y-Delta starting options
- Lower temperature rises
- Copper bar standoffs
- Terminal boards
- Cable glands
- Current transformers
- Surge capacitors and lightning arrestors
- Copper bar rotors
- Custom Polyseal®
- Formed windings (standard for Medium Voltage, optional for Low Voltage)
- Stainless steel shafts on solid shaft motors
- Vibration switches and transmitters



Quantum V - New upgrade of the existing vertical 500 frame WPI / WPII / TEFC motors

## 500 Vertical Frame - HP Rating Matrix

	WPI / WPII		TEFC	
	Min	Max	Min	Max
<b>2-Pole</b>	150	800	150	450
<b>4-Pole</b>	150	800	150	700
<b>6-Pole</b>	150	600	150	600
<b>8-Pole</b>	150	450	150	350
<b>10-Pole</b>	150	300	150	200
<b>12-Pole</b>	150	250	150	250

# WPI Hollow Shaft

Frame												Conduit Box Dimensions					
	BD	P	AG	CD	AJ	AK	BE	BB Min.	BF	BV	EO Min.	AA	AB	AC	AF	XL	XN
509	20.00	36.45	63.45	57.06	14.75	13.50	1.40	0.25	0.69	23.49	6.08	4"-8 NPT	31.27	25.80	14.20	22.70	12.00
511	20.00	36.45	71.45	65.06	14.75	13.50	1.40	0.25	0.69	27.49	6.08	4"-8 NPT	31.27	25.80	14.20	22.70	12.00
513	20.00	36.45	80.45	74.06	14.75	13.50	1.40	0.25	0.69	31.99	6.08	4"-8 NPT	31.27	25.80	14.20	22.70	12.00
509	24.50	36.45	63.45	57.06	14.75	13.50	1.40	0.25	0.69	23.49	6.08	4"-8 NPT	31.27	25.80	14.20	22.70	12.00
511	24.50	36.45	71.45	65.06	14.75	13.50	1.40	0.25	0.69	27.49	6.08	4"-8 NPT	31.27	25.80	14.20	22.70	12.00
513	24.50	36.45	80.45	74.06	14.75	13.50	1.40	0.25	0.69	31.99	6.08	4"-8 NPT	31.27	25.80	14.20	22.70	12.00
509	30.50	36.45	63.45	57.06	26.00	22.00	1.40	0.25	0.81	23.49	6.08	4"-8 NPT	31.27	25.80	14.20	22.70	12.00
511	30.50	36.45	71.45	65.06	26.00	22.00	1.40	0.25	0.81	27.49	6.08	4"-8 NPT	31.27	25.80	14.20	22.70	12.00
513	30.50	36.45	80.45	74.06	26.00	22.00	1.40	0.25	0.81	31.99	6.08	4"-8 NPT	31.27	25.80	14.20	22.70	12.00

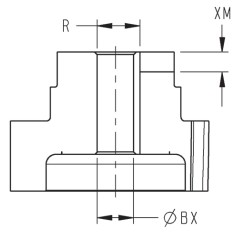
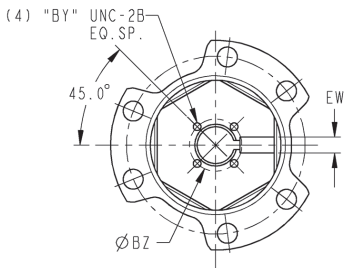
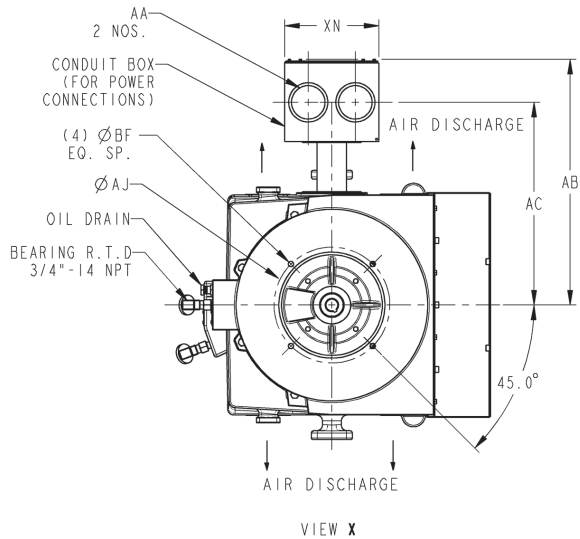
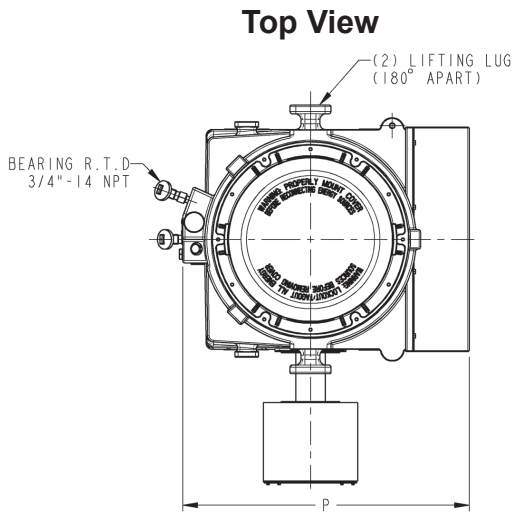

ENLARGED VIEW OF COUPLING

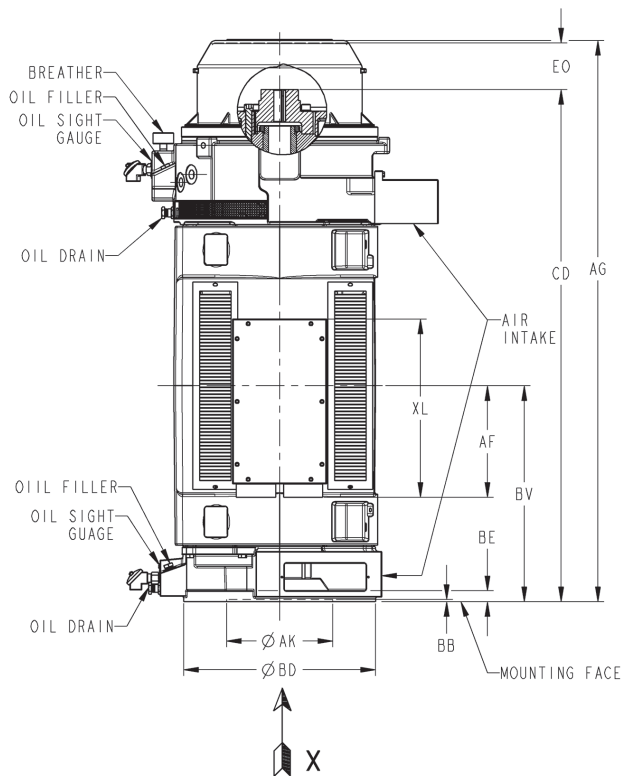

# WPII Hollow Shaft

Frame	BD	P	AG	CD	AJ	AK	BE	BB Min.	BF	BV	EO Min.	Conduit Box Dimensions					
												AA	AB	AC	AF	XL	XN
509	20.00	53.34	63.45	57.06	14.75	13.50	1.40	0.25	0.69	23.49	6.08	4"-8 NPT	31.27	25.80	14.20	22.70	12.00
511	20.00	53.34	71.45	65.06	14.75	13.50	1.40	0.25	0.69	27.49	6.08	4"-8 NPT	31.27	25.80	14.20	22.70	12.00
513	20.00	53.34	80.45	74.06	14.75	13.50	1.40	0.25	0.69	31.99	6.08	4"-8 NPT	31.27	25.80	14.20	22.70	12.00
509	24.50	53.34	63.45	57.06	14.75	13.50	1.40	0.25	0.69	23.49	6.08	4"-8 NPT	31.27	25.80	14.20	22.70	12.00
511	24.50	53.34	71.45	65.06	14.75	13.50	1.40	0.25	0.69	27.49	6.08	4"-8 NPT	31.27	25.80	14.20	22.70	12.00
513	24.50	53.34	80.45	74.06	14.75	13.50	1.40	0.25	0.69	31.99	6.08	4"-8 NPT	31.27	25.80	14.20	22.70	12.00
509	30.50	53.34	63.45	57.06	26.00	22.00	1.40	0.25	0.81	23.49	6.08	4"-8 NPT	31.27	25.80	14.20	22.70	12.00
511	30.50	53.34	71.45	65.06	26.00	22.00	1.40	0.25	0.81	27.49	6.08	4"-8 NPT	31.27	25.80	14.20	22.70	12.00
513	30.50	53.34	80.45	74.06	26.00	22.00	1.40	0.25	0.81	31.99	6.08	4"-8 NPT	31.27	25.80	14.20	22.70	12.00

## Top View

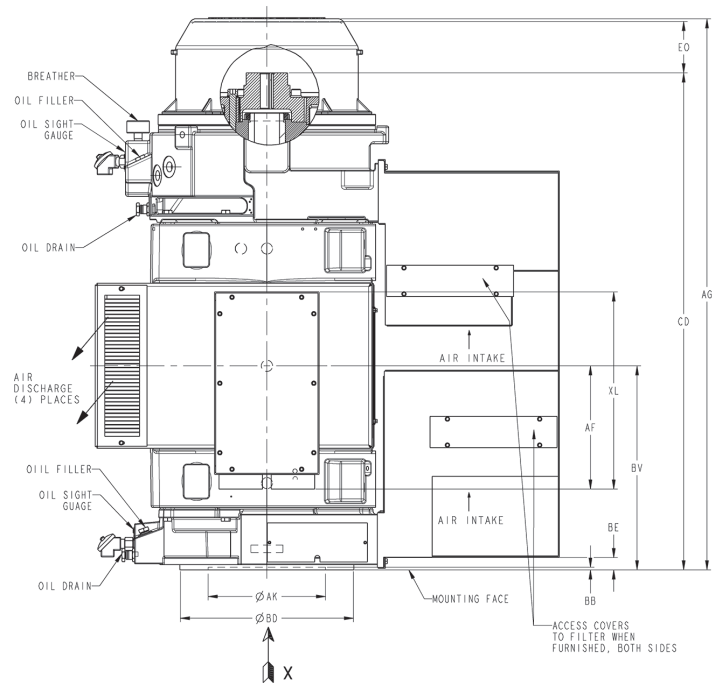
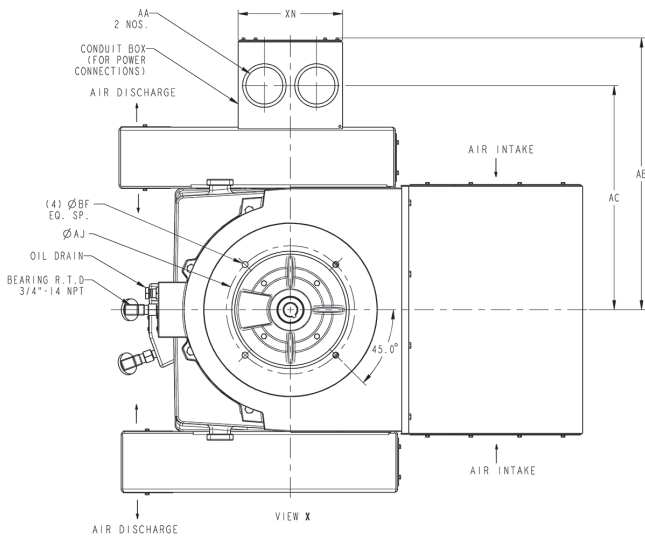
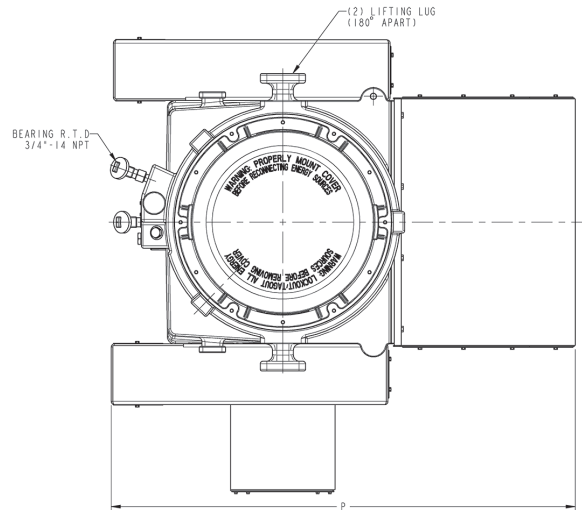
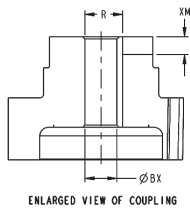
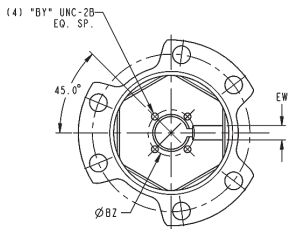

# WPI Solid Shaft

Frame	BD	P	AJ	AK	BE	BB Min.	BF	BV	Conduit Box Dimensions					
									AA	AB	AC	AF	XL	XN
509	20.00	36.45	14.75	13.50	1.40	0.25	0.69	23.49	4"-8 NPT	31.27	25.80	14.20	22.70	12.00
511	20.00	36.45	14.75	13.50	1.40	0.25	0.69	27.49	4"-8 NPT	31.27	25.80	14.20	22.70	12.00
513	20.00	36.45	14.75	13.50	1.40	0.25	0.69	31.49	4"-8 NPT	31.27	25.80	14.20	22.70	12.00
509	24.50	36.45	14.75	13.50	1.40	0.25	0.69	23.49	4"-8 NPT	31.27	25.80	14.20	22.70	12.00
511	24.50	36.45	14.75	13.50	1.40	0.25	0.69	27.49	4"-8 NPT	31.27	25.80	14.20	22.70	12.00
513	24.50	36.45	14.75	13.50	1.40	0.25	0.69	31.49	4"-8 NPT	31.27	25.80	14.20	22.70	12.00
509	30.50	36.45	26.00	22.00	1.40	0.25	0.81	23.49	4"-8 NPT	31.27	25.80	14.20	22.70	12.00
511	30.50	36.45	26.00	22.00	1.40	0.25	0.81	27.49	4"-8 NPT	31.27	25.80	14.20	22.70	12.00
513	30.50	36.45	26.00	22.00	1.40	0.25	0.81	31.49	4"-8 NPT	31.27	25.80	14.20	22.70	12.00

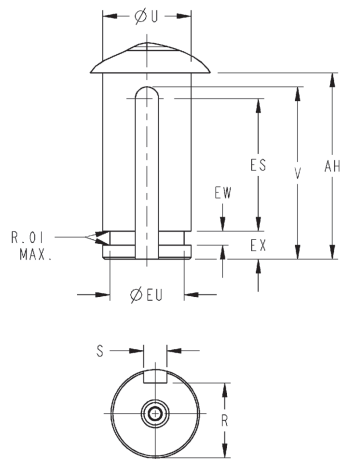

ENLARGED VIEW OF SHAFT EXTENSION

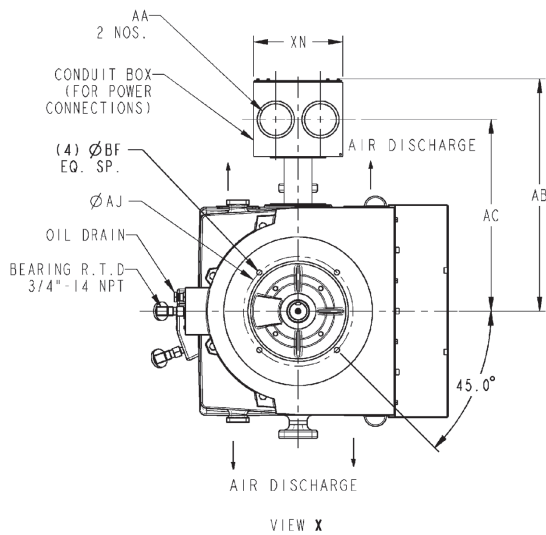
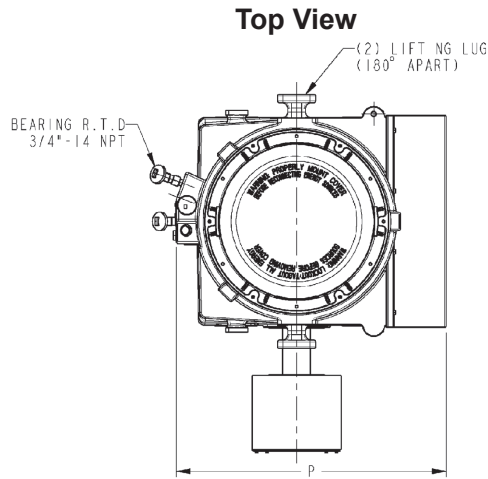

VIEW X

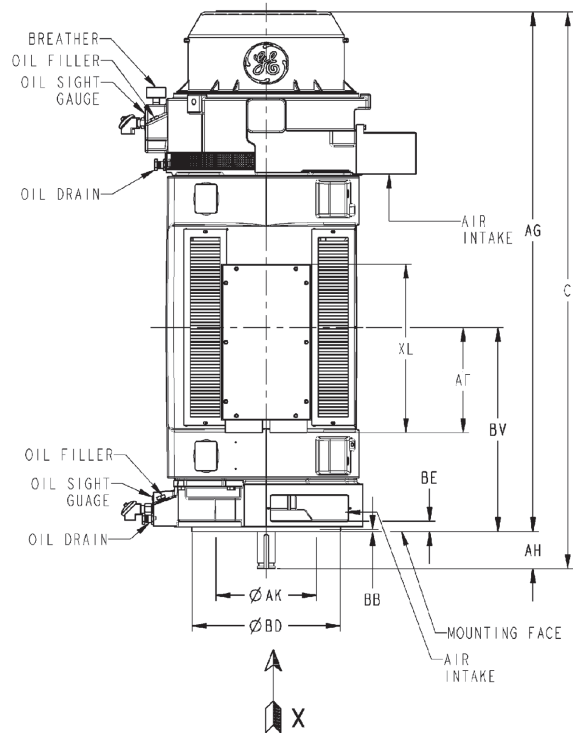

# WPII Solid Shaft

Frame	BD	P	AJ	AK	BE	BB Min.	BF	BV	Conduit Box Dimensions					
									AA	AB	AC	AF	XL	XN
509	20.00	53.34	14.75	13.50	1.40	0.25	0.69	23.49	4"-8 NPT	31.27	25.80	14.20	22.70	12.00
511	20.00	53.34	14.75	13.50	1.40	0.25	0.69	27.49	4"-8 NPT	31.27	25.80	14.20	22.70	12.00
513	20.00	53.34	14.75	13.50	1.40	0.25	0.69	31.99	4"-8 NPT	31.27	25.80	14.20	22.70	12.00
509	24.50	53.34	14.75	13.50	1.40	0.25	0.69	23.49	4"-8 NPT	31.27	25.80	14.20	22.70	12.00
511	24.50	53.34	14.75	13.50	1.40	0.25	0.69	27.49	4"-8 NPT	31.27	25.80	14.20	22.70	12.00
513	24.50	53.34	14.75	13.50	1.40	0.25	0.69	31.99	4"-8 NPT	31.27	25.80	14.20	22.70	12.00
509	30.50	53.34	26.00	22.00	1.40	0.25	0.81	23.49	4"-8 NPT	31.27	25.80	14.20	22.70	12.00
511	30.50	53.34	26.00	22.00	1.40	0.25	0.81	27.49	4"-8 NPT	31.27	25.80	14.20	22.70	12.00
513	30.50	53.34	26.00	22.00	1.40	0.25	0.81	31.99	4"-8 NPT	31.27	25.80	14.20	22.70	12.00

# WPI/WPII Solid Shaft

**Table 1: Shaft Extension for 3600 RPM, 2-pole (Dimensions are in inches)**

Frame	U	EU	ES	V Min.	S	R	EW	EX	AH
509	2.125	1.750	3.150	4.150	0.500	1.845	0.375	0.750	4.50
511	2.375	2.000	3.558	4.620	0.625	2.006	0.375	0.750	5.00

**Table 3: Shaft Extension Tabulation based on Recommended Shaft "U" Dimension (inches) for 4-pole and Slower**

U	EU	ES	V Min.	S	R	EW	EX	AH
2.375	2.000	3.558	4.620	0.625	2.006	0.375	0.750	5.00
2.625	2.125	3.600	5.300	0.625	2.275	0.500	1.000	5.00
2.875	2.375	4.100	5.480	0.750	2.450	0.500	1.000	6.00

**Table 2 Recommended Shaft "U" Dimension (in inches) versus HP and Speed for 4-pole and Slower**

HP	Speed				
	1800	1200	900	720	600
100	-	-	-	2.125	2.125
125	-	-	-	2.125	2.375
150	-	-	-	2.375	2.375
200	-	-	2.375	2.625	2.625
250	-	2.375	2.625	2.875	2.875
300	-	2.625	2.625	2.875	-
350	-	2.625	2.875	-	-
400	2.375	2.625	2.875	-	-
450	2.375	2.875	-	-	-
500	2.625	2.875	-	-	-
600	2.625	2.875	-	-	-
700	2.875	-	-	-	-
800	2.875	-	-	-	-

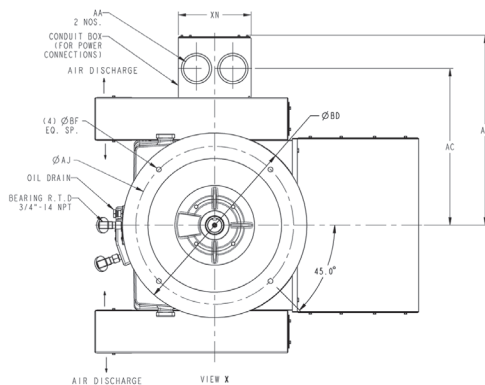
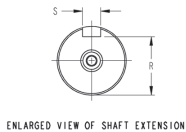
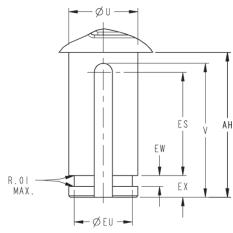

**Top View**

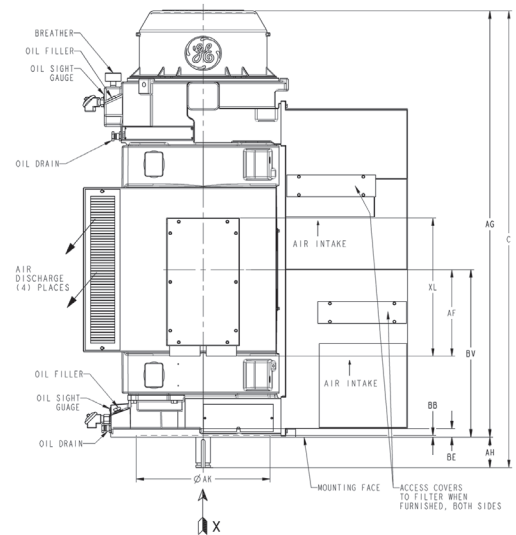
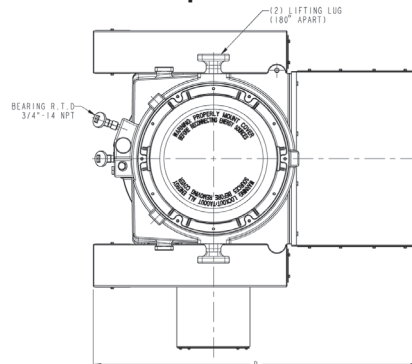

# TEFC Hollow Shaft

Frame	BD	P	AG	CD	AJ	AK	BE	BB Min.	BF	BV	EO Min.	Conduit Box Dimensions					
												AA	AB	AC	AF	XL	XN
509	20.00	40.24	66.39	56.50	14.75	13.50	1.40	0.25	0.69	12.00	9.18	4"-8 NPT	25.40	19.94	8.50	22.70	12.00
511	20.00	40.24	74.39	64.50	14.75	13.50	1.40	0.25	0.69	12.00	9.18	4"-8 NPT	25.40	19.94	8.50	22.70	12.00
513	20.00	40.24	83.39	73.50	14.75	13.50	1.40	0.25	0.69	12.00	9.18	4"-8 NPT	25.40	19.94	8.50	22.70	12.00
509	24.50	40.24	66.39	56.50	14.75	13.50	1.40	0.25	0.69	12.00	9.18	4"-8 NPT	25.40	19.94	8.50	22.70	12.00
511	24.50	40.24	74.39	64.50	14.75	13.50	1.40	0.25	0.69	12.00	9.18	4"-8 NPT	25.40	19.94	8.50	22.70	12.00
513	24.50	40.24	83.39	73.50	14.75	13.50	1.40	0.25	0.69	12.00	9.18	4"-8 NPT	25.40	19.94	8.50	22.70	12.00
509	30.50	40.24	66.39	56.50	26.00	22.00	1.40	0.25	0.81	12.00	9.18	4"-8 NPT	25.40	19.94	8.50	22.70	12.00
511	30.50	40.24	74.39	64.50	26.00	22.00	1.40	0.25	0.81	12.00	9.18	4"-8 NPT	25.40	19.94	8.50	22.70	12.00
513	30.50	40.24	83.39	73.50	26.00	22.00	1.40	0.25	0.81	12.00	9.18	4"-8 NPT	25.40	19.94	8.50	22.70	12.00

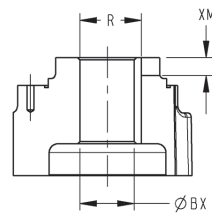
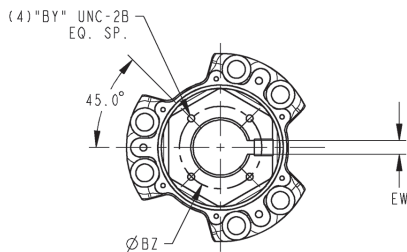

ENLARGED VIEW OF COUPLING

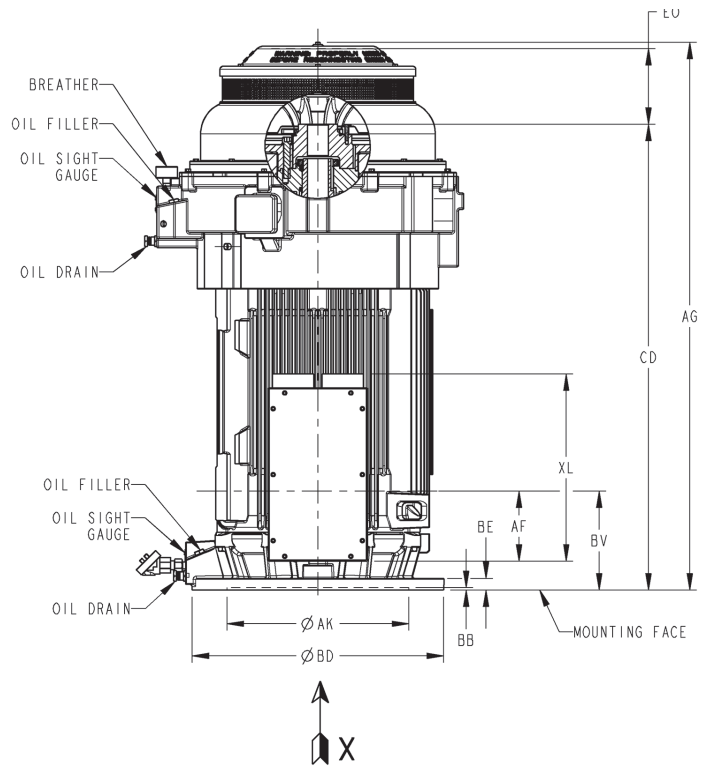
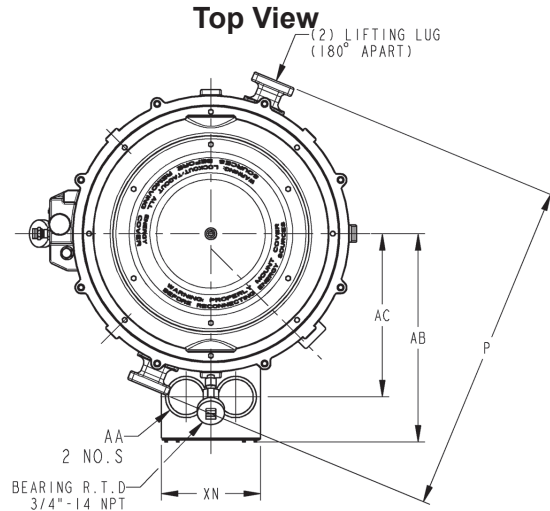
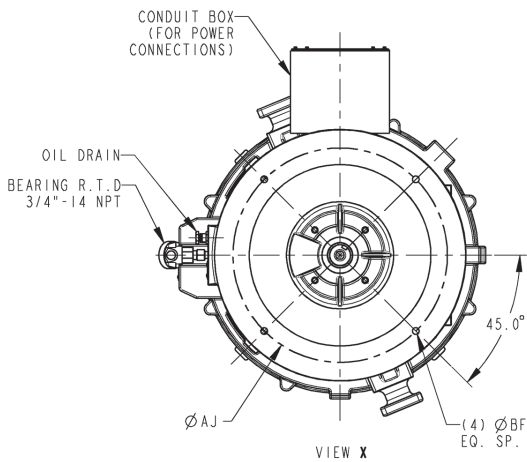

# TEFC Solid Shaft

Frame	BD	P	AJ	AK	BE	BB Min.	BF	BV	Conduit Box Dimensions					
									AA	AB	AC	AF	XL	XN
509	20.00	40.24	14.75	13.50	1.40	0.25	0.69	12.00	4"-8 NPT	25.40	19.94	8.50	22.70	12.00
511	20.00	40.24	14.75	13.50	1.40	0.25	0.69	12.00	4"-8 NPT	25.40	19.94	8.50	22.70	12.00
513	20.00	40.24	14.75	13.50	1.40	0.25	0.69	12.00	4"-8 NPT	25.40	19.94	8.50	22.70	12.00
509	24.50	40.24	14.75	13.50	1.40	0.25	0.69	12.00	4"-8 NPT	25.40	19.94	8.50	22.70	12.00
511	24.50	40.24	14.75	13.50	1.40	0.25	0.69	12.00	4"-8 NPT	25.40	19.94	8.50	22.70	12.00
513	24.50	40.24	14.75	13.50	1.40	0.25	0.69	12.00	4"-8 NPT	25.40	19.94	8.50	22.70	12.00
509	30.50	40.24	26.00	22.00	1.40	0.25	0.81	12.00	4"-8 NPT	25.40	19.94	8.50	22.70	12.00
511	30.50	40.24	26.00	22.00	1.40	0.25	0.81	12.00	4"-8 NPT	25.40	19.94	8.50	22.70	12.00
513	30.50	40.24	26.00	22.00	1.40	0.25	0.81	12.00	4"-8 NPT	25.40	19.94	8.50	22.70	12.00

# WPI/WPII Solid Shaft

**Table 1: Shaft Extension for 3600 RPM, 2-pole (Dimensions are in inches)**

Frame	U	EU	ES	V Min.	S	R	EW	EX	AH
509	2.125	1.750	3.150	4.150	0.500	1.845	0.375	0.750	4.50
511	2.375	2.000	3.558	4.620	0.625	2.006	0.375	0.750	5.00

**Table 3: Shaft Extension Tabulation based on Recommended Shaft "U" Dimension (inches) for 4-pole and Slower**

U	EU	ES	V Min.	S	R	EW	EX	AH
2.375	2.000	3.558	4.620	0.625	2.006	0.375	0.750	5.00
2.625	2.125	3.600	5.300	0.625	2.275	0.500	1.000	5.00
2.875	2.375	4.100	5.480	0.750	2.450	0.500	1.000	6.00

**Table 2 Recommended Shaft "U" Dimension (in inches) versus HP and Speed for 4-pole and Slower**

HP	Speed				
	1800	1200	900	720	600
100	-	-	-	2.125	2.125
125	-	-	-	2.125	2.375
150	-	-	-	2.375	2.375
200	-	-	2.375	2.625	2.625
250	-	2.375	2.625	2.875	2.875
300	-	2.625	2.625	2.875	-
350	-	2.625	2.875	-	-
400	2.375	2.625	2.875	-	-
450	2.375	2.875	-	-	-
500	2.625	2.875	-	-	-
600	2.625	2.875	-	-	-
700	2.875	-	-	-	-
800	2.875	-	-	-	-

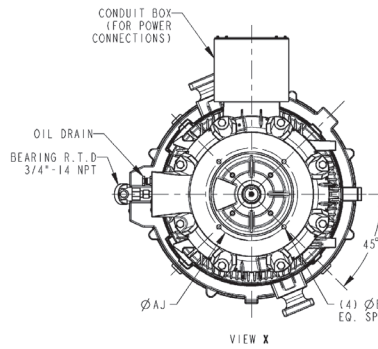
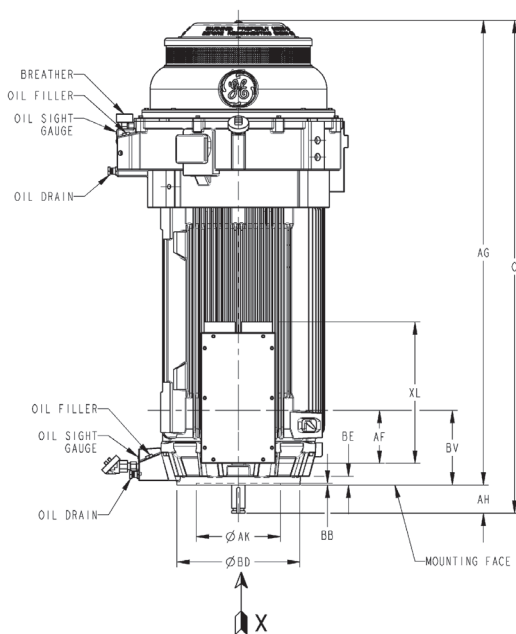

**Top View**

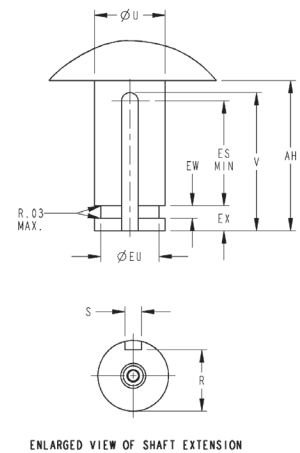
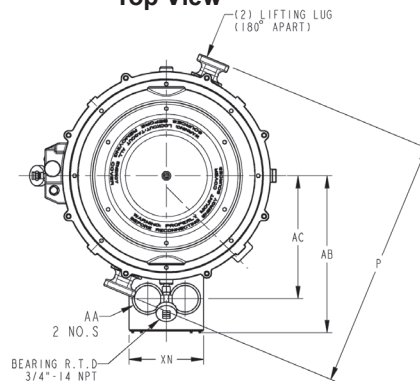

**ENLARGED VIEW OF SHAFT EXTENSION**



# Thrust Values in $Ib_f$

WPI/WPII 509 Frame					TEFC 509 Frame			
Sync RPM	100%	175%	300/360%	500%	Sync RPM	100%	175%	300/500%
3600	4800	8400	11400 (W)		3600	4800	8400	11400 (W)
1800	8100	14200	22700	43200 (W)	1800	12400	19600	39200
1200	9600	16600	26500	43000 (W)	1200	13900	22000	39000
900	10700	18400		43000	900	15200	24600	39000
720	11700	19900		43000	720	16000	25300	39000
600	12500	21300		43000	600	16800	26400	39000

WPI/WPII 5011 Frame					TEFC 5011 Frame			
Sync RPM	100%	175%	300/360%	500%	Sync RPM	100%	175%	300/500%
3600	4500	8100	11100 (W)		3600	4500	8100	11100 (W)
1800	7700	13800	22300	42800 (W)	1800	12000	19200	38800
1200	9200	16200	26100	42600 (W)	1200	13500	21600	38600
900	10300	18000		42600	900	14800	24200	38600
720	11300	19500		42600	720	15600	24900	38600
600	12100	20900		42600	600	16400	26000	38600

WPI/WPII 5013 Frame					TEFC 5013 Frame			
Sync RPM	100%	175%	300/360%	500%	Sync RPM	100%	175%	500%
1800	7300	13400	21900	42400 (W)	1800	11600	18800	38400
1200	8700	15700	25600	42100 (W)	1200	13000	21100	38100
900	9800	17500		42100	900	14300	23700	38100

(W) – This rating requires water cooling on the upper end thrust bearings.



## Experience

GEIM builds upon an extensive history in the Vertical Turbine Pump motor business. We have been designing and building Vertical Turbine Pump Motors for over 50 years. Select customers have access to our application experts who all have an average of over 30 years in the motor industry to solve all of your custom application engineering needs.

## The Leading Manufacturer of Motors and Drives

